

FIRE ALARM SYSTEM - SUBMITTAL REQUIREMENTS APPLICATION CHECKLIST

Page 1 of 3



BAKERSFIELD FIRE DEPT. Prevention Services

2101 H Street
Bakersfield, CA 93301
Tel.: (661) 326-3979
Fax: (661) 852-2171

The following requirements have been established for the specifications for all fire alarm systems and submittal of plans being installed within this jurisdiction to the Bakersfield Fire Prevention Services Division. ***Submittals not conforming to these minimum requirements will be returned as incomplete.***

These requirements apply to New Construction, Existing Buildings, with the exception of Single Family Residences.

Fire alarm systems shall be designed, installed, and maintained in accordance with NFPA 72-2002. All Central Stations must meet the requirements listed in the NFPA. Central Station must be UL listed; and a copy of Certificate of Compliance by UL is to be submitted with plans.

SECTION I. DOCUMENTATION SUBMITTAL REQUIREMENTS

Yes No

1. Provide three copies of plans and one set of original equipment data sheets.
NOTE: Hand drawn plans will not be accepted.
2. When project is part of a larger complex, *show a full site plot plan as to where the project is with relationship to the other suites.*
NOTE: Alarm systems under one roof must be tied together.
3. Provide current California State Fire Marshal listing sheets for all devices and equipment to be installed.
4. Provide booklet (Device Compatibility Document), with all new control panel installations.
5. The Fire alarm System Submittal Cover Sheet must be filled out complete and shall be included in the submittal requirements. (See attached copy)
6. A Certificate of Completion document shall be completed and signed by the Installer and the Servicing Company upon completion of project.

SECTION II. ALARM PLANS SUBMITTAL REQUIREMENTS

Yes No

1. Provide three copies of plans and one set of original equipment data sheets. **Hand drawn plans will not be accepted** as mentioned in Section 1 above.
- a. All symbols shall conform to NFPA 170 standards. (See attached symbols design.)
- b. Drawings shall be legible, scaled and contain only the fire alarm components – **no overlays.**
- c. Provide details for conductors on the plans, including type, manufacturer, and size.
2. Fire alarm plans shall provide the following information:
- a. Voltage drop calculations.
- b. Circuit, power supply (battery) calculations, standby, and alarm.
- c. Point to point configuration of all devices to the control panel.
- d. Complete sequence of operation that shows alarm, supervisory, and trouble signals per application.
- e. A complete symbol key on the building floor plan device layout pages.
3. Floor plans to provide end of line devices, conduit wire runs, conduit sizes. *Floor plans must show the following location of:*
- a. Sprinkler rise, if applicable.
- b. Post indicator valve (PIV).
- c. Check valves.
- d. Tamper.
- e. Control panel.
- f. Annunciator
- g. Ceiling smoke/heat detectors.



FIRE ALARM SYSTEM - SUBMITTAL REQUIREMENTS
APPLICATION CHECKLIST

Page 2 of 3















- h. Duct smoke detectors and remote lamp or test station locations.
- i. Zones.
- j. Pull stations.
- k. All audible and visual devices (show candela and decibel ratings).

FIRE ALARM SIGNALS

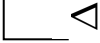
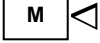
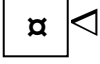







- A. **Alarm Initiating Devices:**
A signal indicating a fire emergency
 - A. Automatic water flow devices. (Maximum time is 5 minutes).
 - B. Manual fire alarm station (pull station).
 - C. Automatic fire detectors (smoke or heat detectors).
 - D. Wet/dry chemical systems.
 - E. Electric fire pumps, including running alarm or supervisory and phase reversal power failure.
 - F. Engine-driven fire pumps, failure to start, controller off automatic and trouble (for example: low oil, high temperature over speed).
 - G. Steam turbine fire pumps-all associated devices.
 - H. Mechanical operation of a release mechanism.
 - I. Differential pressure devices.
- B. **Supervisory Initiating Devices:**
A signal indicating an "off-normal" condition exists on the extinguishing system.
 - A. Control valve switch device.
 - B. High and low air pressure devices.
 - C. High and low water tank level and temperature switch devices.
 - D. Low water pressure for public water supplies.
 - E. Low and high building temperature sensing devices.
 - F. Post indicator valves.
 - G. Stem and yoke valves.
 - H. Smoke duct detector devices.
 - I. Tamper device.
 - J. Gravity water tanks.
 - K. Building temperature, including valve closet, fire pump house.
- C. **Trouble:**
A signal indicating a problem with the fire control panel or associated wiring which may render the system inoperable
 - A. Loss of primary power (120 VAC).
 - B. Loss of secondary power (battery).
 - C. A break in the supervised wiring to an initiating device, indicating appliance or extinguishing agent release device.

NFPA 170 STANDARDS For FIRE SAFETY SYMBOLS

ALARM SYMBBOLS

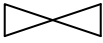
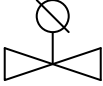
 OR 	Fire Alarm Control Panel FACP denotes Panel FACU denotes Unit
 OR 	Fire Alarm Keypad Fire System Annunciator
	Smoke Detector <i>P denotes Photoelectric</i> <i>I denotes Ionization</i> <i>BT denotes Beam Transmitter</i> <i>BR denotes Beam Receiver</i>
	Smoke Detector for Duct
	Heat Detector <i>F denotes Fixed Temperature</i> <i>R denotes Rate of Rise</i> <i>R/C denotes Rate Compensation</i>
	Manual Station
	Pull Station
	Horn
	Mini Horn
	Horn Strobe
	Strobe, Indicator Lamp, Light
	Fire Damper
	Smoke Dampers
	Speaker (Voice)
	Speaker (Voice)
	Magnetic Door Holder

SPRINKLER SYMBOLS

	Bell, Gong
	Sprinkler Riser
	Siamese Fire Dept. Connection
	Free Standing Siamese Connection
	Valve <i>PIV denotes POST Indicator Valve</i> <i>OS&Y denotes Outside Stem & Yoke</i> <i>BF denotes Butterfly</i>
	Valve Tamper Switch
	Tamper Switch
	Flow Switch
	Backflow Preventer – Double Check Valve
	Fire Pump